

Fast and  
energy saving

TDR 5 Programmable eco

**The Turbo Deli Rotisserie is the fastest original rotisserie in the industry. The TDR's cavity is fed with air, cooking a rotisserie chicken as it is meant to be: crispy and delicious while maintaining an attractive appearance for hours.**

The TDR pushes the air throughout the cavity, resulting in an improved heat transfer on the products and consequently in a reduced electricity consumption during the preparation process.

Thanks to eco-cooking the TDR saves 5% additional energy. Add to this the improved heat transfer on the products and a fast preparation process and you have yourself the most energy-efficient rotisserie with a high output.

The Cook Correction Technology corrects alterations in the cooking cycle that are due to half-loads, overloads, or products with a difference in temperature. It measures abnormalities in the temperature curve and corrects the cycle automatically, ensuring food-safety and energy-efficient cooking.



Programmable controls



Eco-cooking



## Features TDR 5 Programmable

### Top features

- Controls with programmable settings
- 99 programs with up to 3 cook stages per program
- Efficient heat transfer reduces energy consumption
- Cook correction to control food safety
- Eco-cooking, saves on energy consumption

### Standard characteristics

- 5 Meat fork, V-spit, basket or rack positions
- Rotor for up to 20 chicken (1,2 kg) per batch
- USB connection for easy transfer of data and programs
- Boost functionality to add extra time
- Outstanding food quality: high-speed convection for even cooking
- Outstanding food quality: radiant heat for uniform browning
- Striking cooking theatre due to large glass surface and brilliant lighting
- Safety stop when opening the door
- No water and drain connections needed

### Accessories

- Meat forks (included)
- Multi-purpose baskets
- V-spits and chicken racks
- Matching stand on castors

### Optional

- Double stacked unit
- Ventless hood



Ventless hood (optional)



Large product view

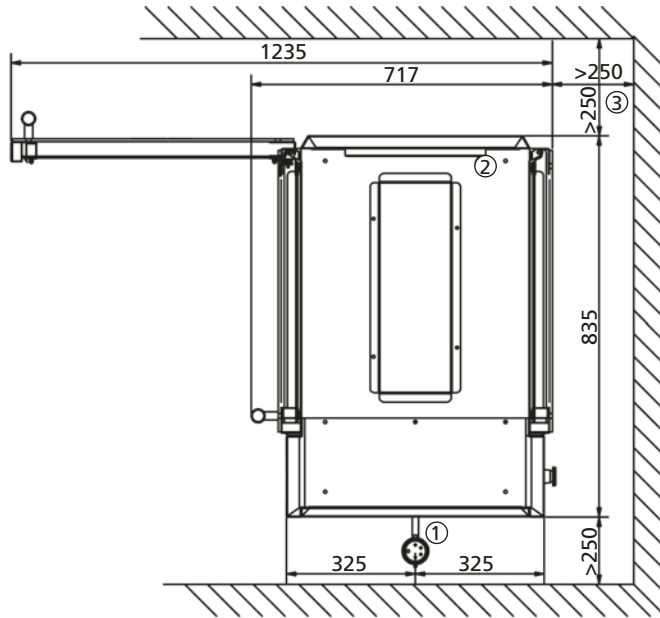

## TDR 5 Programmable

- 1 Power cable, 2.2 m
- 2 Exhaust opening
- 3 Space to the wall
- 4 Location for socket

### Dimensions TDR 5

Width	845 mm
Depth	717 mm
Height	910 mm
Height incl. stand	1726 mm

### Technical data TDR 5

Net weight	130 kg
Gross weight	152 kg
Voltage	3N~ 400/230 V
Frequency	50/60 Hz
Power	6.6 kW

### Dimensions TDR 5+5

Width	845 mm
Depth	717 mm
Height	1790 mm

### Technical data TDR 5+5

Net weight	266 kg
Gross weight	306 kg
Voltage	3N~ 400/230 V
Frequency	50/60 Hz
Power	13.2 kW

Specifications and technical data are subject to amendment without prior notice.

These are basic drawings. For more detailed technical information, please refer to the installation manual at [www.frijado.com](http://www.frijado.com).

