



**BERTRAND
PUMA**

La griffe boulangère



FERMENTOLEVAIN®

leaven processor

FERMENTOLEVAIN®

the high-tech tradition



FL200

FL100

FL60

FL30

FERMENTOLEVAIN® are equipments allowing both preparation and conservation of liquid leaven to be added to the different final dough mixtures.



■ FERMENTOLEVAIN® : a name that has become part of baking history

In 1994, Bertrand-Puma marketed its first Fermentolevain®, thus reproducing the natural bread-making process. Considered to be revolutionary, this invention offered a new approach to taste and flavours and received the Innovation Trophy at the European trade fair.

Professionals took a keen interest in it, having rapidly understood the advantages it could offer to make an alternative to «industrial» bread. It is a way of resisting standardisation of taste and of focusing on genuine baking know-how.

A «legend» was born and the name Fermentolevain® or «Fermento» soon became a reference, even becoming part of the trade's everyday vocabulary.

The assets of Fermentolevain®

- + Consistency of quality and taste
- + Rapid development of leaven
- + Perfect, controlled hygiene
- + Simple use and mixing
- + A 100% organic process
- + An economical and profitable product
- + The «Chef» made directly into the tank



■ Better storage and working of the dough :

Leaven bread can be **stored and preserved longer** than common bread, thanks to the acidity released by the bacterias, which slows down the staling. This kind of bread also has a thicker crust that acts like a protective cover. It helps to keep the humidity in the bread, and limits the drying of the crumb.

Unique and widely known for their characteristic **flavor**, leaven breads have a **brighter and more golden color** after baking.

Using natural leaven shortens fermentation and kneading time. As the glutinous tissue is much more structured, mechanical operations are easier : the dough is more **supple**, which facilitates lamination and **moulding**, cutting is sharper and the dough is less sticky.

■ Taste first :

Fine gourmets or not, consumers will always love tasty bread. The hand-crafted flavour of a leaven product is popular as the crunchiness of the crust, irregular air cell structures in the dough and its cream colour give it a more rustic feel, reminiscent of old-style bread.

The loaves obtained are consistent, rich, with a slightly lactic taste that can be altered with more sour flavours by adjusting the « Chef », the temperature and the proofing time.



Some will say that you don't need a machine to make natural leaven bread... They're right!
However, a conscientious professional will strive to obtain a leaven bread of constant quality and taste
in irreproachable hygiene conditions.

■ The right quantity, at the right time :

The Fermentolevain® range guarantees that your natural leaven capacity matches your production.

All our Fermentolevain® models allow you to keep your basis leaven for several days and produce refreshed leaven in the strictest hygiene conditions. It is now possible to make the leaven « **Chef** » in Fermentolevain®.

All of them, even with the smallest tank capacity have a **heating cord** and **cooling coil** designed to promote maturing and storage of natural leaven.

You can modulate storage length to adapt to your leaven production and work hours.

The ferments are redeveloped at each refreshed leaven, as a result of the unique mixing and the control of the temperature. It is possible to preserve the leaven for 3 days without a refreshed leaven.



■ Control the flavour of your bread :

Controlling the development of leaven means controlling the savour and taste of your products.

By adjusting temperatures, you can easily vary the ratio between acetic acid and lactic acid, thus playing with savours and finding what most suits your customers.



■ Irreproachable hygiene :

Already a priority when Fermentolevain[®] was first developed in 1994, the notions of cleanability and hygiene have been modernized.

The materials used comply with all food-making requirements: the paddles and scraper in the tank are, for example, **removable without tools** and easy to clean. They can be washed in a dishwasher. Fermentolevain[®] offers an **automatic washing cycle** (2 cycles: economic and full) that allows a quick and easy clean up. A **hand spray** effortlessly reaches every corner of the tank and the tools (not available on the FL 30 models).

There is an opening to add ingredients directly into the tank or through the tiltable sieve. A plexiglas screen allows visual control without jeopardising hygiene. Fermentolevain[®] becomes more ergonomic with its unique racking valve, **anti-drip** and without sediments.

■ New design :

Fermentolevain[®] has a new sleek and refined design. The frame, as well as the housing, are made of **stainless steel**. A frontal safety shield made of resin protects the frame from accidental blows, thus preventing the deterioration of the stainless steel. The tank has been redesigned to improve draining and limit retention areas. A **low level probe** keeps you informed on how much leaven is left in the tank, and an **anti-overflowing probe** warns you if the fermentation becomes too important.

Fermentolevain[®] has many new functionalities : a **scaling system** (option) integrated into the machine gives you real-time information about the amount of leaven present in the tank. Its double tare weight system facilitates the withdrawal of leaven and allows the addition of ingredients without preparing the quantities in advance. It is now also possible to inject water directly into the tank. The latest generation of Fermentolevain[®] has a new 7 inches **touch control panel : V-Touch**.

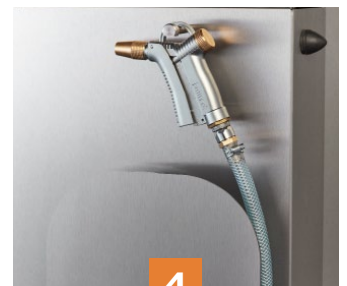
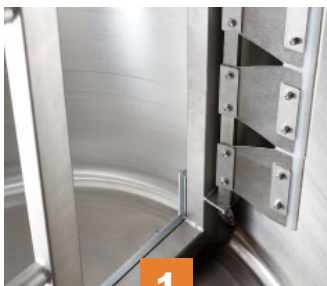

- 1 The tank is in food-safe stainless steel as are the paddles that are easy to dismantle and do not require specific tools.
- 2 A performing mixing tool (unchanged form, patented) ensures an homogeneous mixing from top to bottom
- 3 Racking valve preventing any sediment from settling at the bottom
- 4 A hand spray allows easy cleaning of the tank, paddles and scrapers
- 5 Sturdy and efficient scrapers, with dissociated strips.



V-TOUCH

Using a Fermentolevain® becomes child's play !

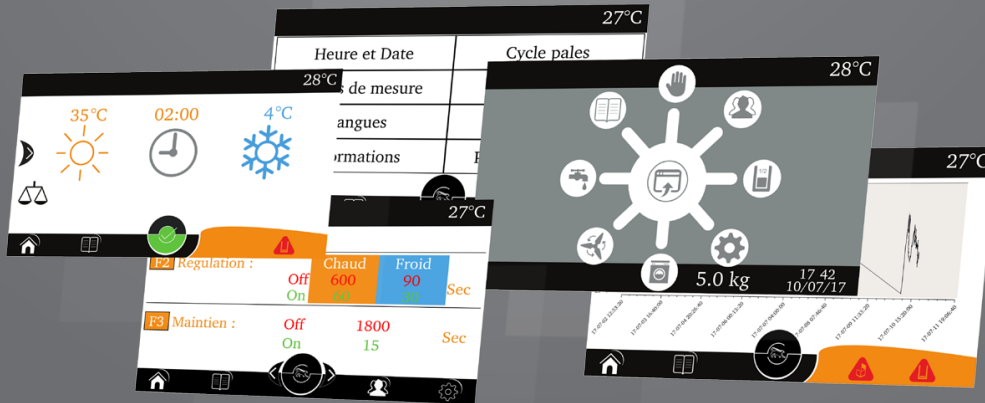

■ Simplified management with the V-TOUCH

The V-Touch is an **intuitive control panel** that gives an easy access to all the machine's functionalities. The user locates and reaches quickly many parameters from the main menu.



Manual mode



User profile



Half tank mode



Settings



Washing
cycle



Paddles rotation



Water
injection



Recipes

Storage cycles are easily monitored using clear and intuitive control panels. With just a glance, you can identify the current cycle's phase: **blue for conservation, orange for fermentation.**

■ The breads of the world at your reach

Efficient, the control panel guides the baker step by step thanks to pre-registered or customizable programs.

Four programmed recipes, conceived by master bakers, will assist you during the production of a final leaven. Two additional recipes will help you chose the type of refreshed leaven, lactic or acetic. You can also create your own recipes (up to 15) by adjusting temperature, cycle length and save them in the machine's memory.

Find even more ideas in the recipe book that comes with Fermentolevain®: 16 leaven bread recipes from all around the world !

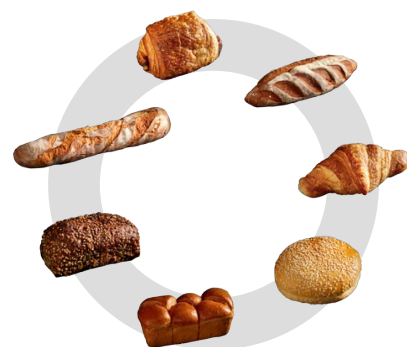

■ Control with ease

Adaptable, the V-Touch fits every baker and offers a comfortable and personalized navigation. Parameters, such as the language used or the units of measure, can be modified easily, and it is possible to create several user profiles, protected by password.

The V-Touch gives you a continued access to the performed actions log, and allows you to observe the descriptive statistics and graphic displays of Fermentolevain®'s activity (exportable).

In case of a power-cut or if the machine is unplugged, the current state of the cycle is memorized.

27°C	
Heure et Date	Cycle pales
Unités de mesure	Inertie
Langues	Luminosité
Informations	Paramètres usine

27°C	
Fonctionnement :	1:31:28
Groupe froid :	0:00:00
Cordon chauffant :	0:36:21
Pales :	0:22:33
Dernière coupure de courant :	0:09:43
Date :	10/07/17 à 17:41

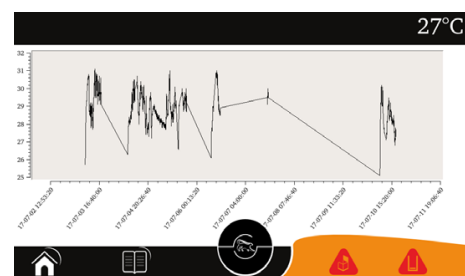

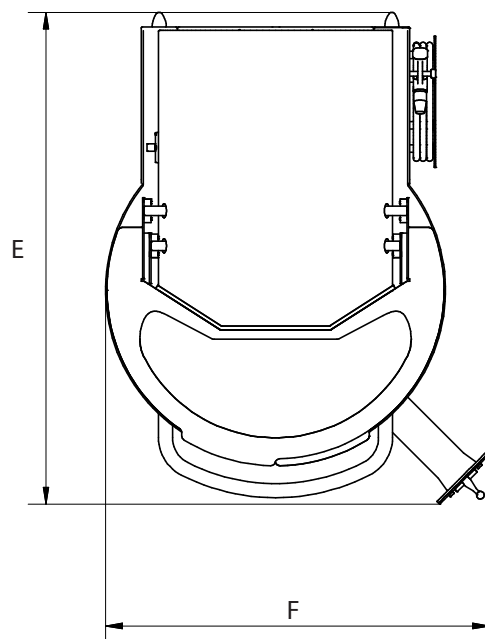
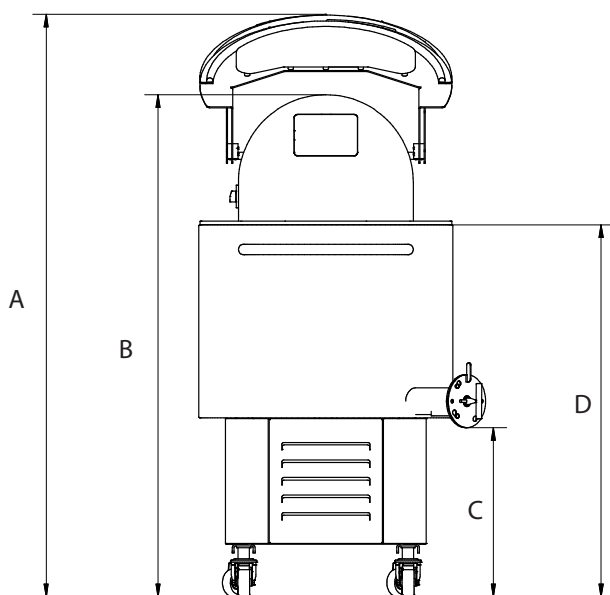

Models	FL 30	FL 60	FL 100	FL 200
Tank useful capacity (kg)	30	60	100	200
Weight (kg) when empty	195	225	270	405
Electrical supply	400V / Tri+N+T (other on request)			
Power (kW) (kW)	1,1	1,5	2,1	3,3
Heating coil power (W)	350	525	700	1050
A - Height with lid open (mm)	1530	1830	2075	2155
B - Height (mm)	1250	1430	1690	1810
C - Valve height (mm)	440	440	440	535
D - Working height (load) (mm)	880	1060	1320	1320
E - Depth (mm)	1010	1050	1050	1300
F - Width (mm)	735	820	820	1040
Temperature decrease	around 6°C per hour			
Water supply	—	Pipe Ø15 internal		
Refrigerating gas	R452A			
Recipe storage	15 recipes			
Hand spray	—	●	●	●
Basis leaven conservation	●	●	●	●
Alert buzzer	●	●	●	●
Anti-overflowing probe	●	●	●	●
Low level probe	—	●	●	●
Scaling system	—	○	○	○

● Standard ○ Option — Not available