

In-store impulse-generating merchandiser

Multi Deck 24 - 4 level



Placing impulse food products near checkouts has proven to be a successful strategy in today's grab-and-go market. With the Fri-Jado Multi Deck, your customers can pick up delicious, hot, pre-packaged snacks and meal solutions practically anywhere in the store.

Hot air is blown from the front of the shelf and circulates within the shelf surface resulting in optimum air circulation around the hot product.

Large glazed walls give a 180-degree view of the products. The appealing design gives outstanding product presentation which is sure to boost impulse sales.

Features MD 24 - 4 Premium

Top features

- Self-serve heated Multi Deck display unit
- Innovative airflow technology: no hot or cold spots
- Boosts impulse sales

Standard characteristics

- 24" wide - 4 level display
- Product temperature maintained at 149°F
- Ideal for chicken, wraps, snacks, soups etc.
- Upright design saves space
- Total display capacity of 10.76ft²
- Footprint of 5.38ft²
- Safety lighting on each level
- Shatter-resistant clear side glass for optimum safety
- Saves up to 20% on energy by air-curtain technology on each shelf
- Safe holding temperature for up to four hours
- Angled shelves provide optimum product visibility
- Illuminated changeable sign at top and price strips on each shelf
- Front bumpers to protect from shopping carts
- Solid back as standard
- 98% recyclable (environmentally friendly)
- Plug-and-play

Accessories

- Customer-side temperature indicator
- Lower skirts (covering wheels)

Optional

- Doors at rear (pass through)
- Front doors



Optimum product visibility



Signage



Rear doors (optional)



Keeps hot food at 149°F

MD 24-4 Premium

1 Power cable, 10 ft.

Dimensions

| | |
|--------|---------|
| Width | 23 5/8" |
| Depth | 31 1/2" |
| Height | 77 5/8" |

Technical data

| | |
|--------------|------------|
| Net weight | 455 lbs |
| Gross weight | 542 lbs |
| Voltage | 208 V |
| Frequency | 60 Hz |
| Power | 3 kW |
| Plug | NEMA 6-20P |

Specifications and technical data are subject to amendment without notice

These are basic drawings. For more detailed technical information, please refer to the installation manual at www.frijado.com.

Patent number: EP2309897

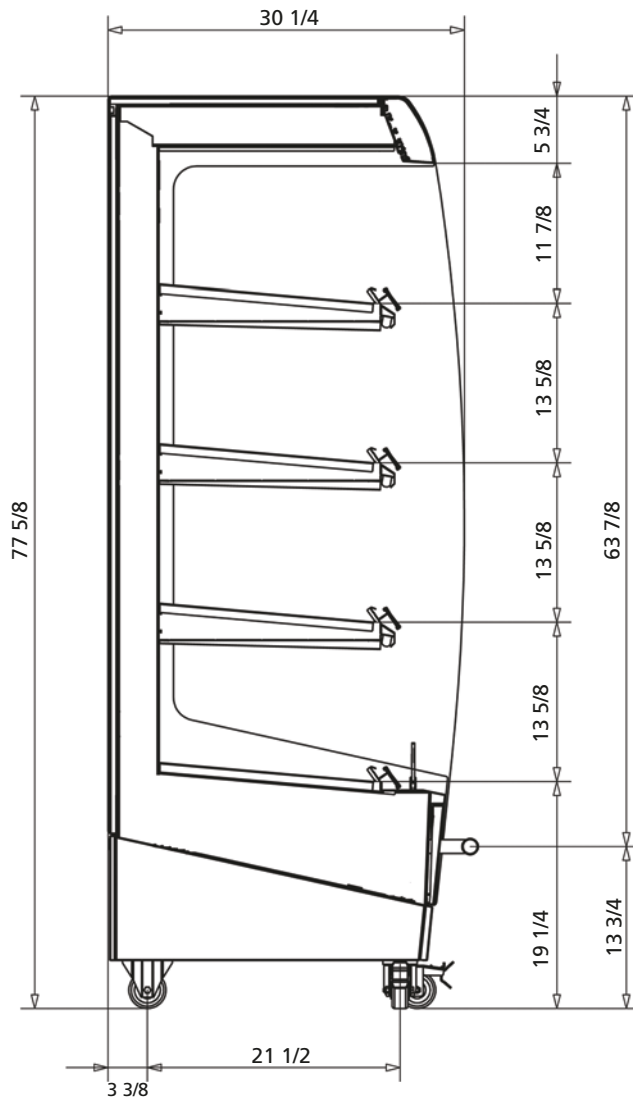
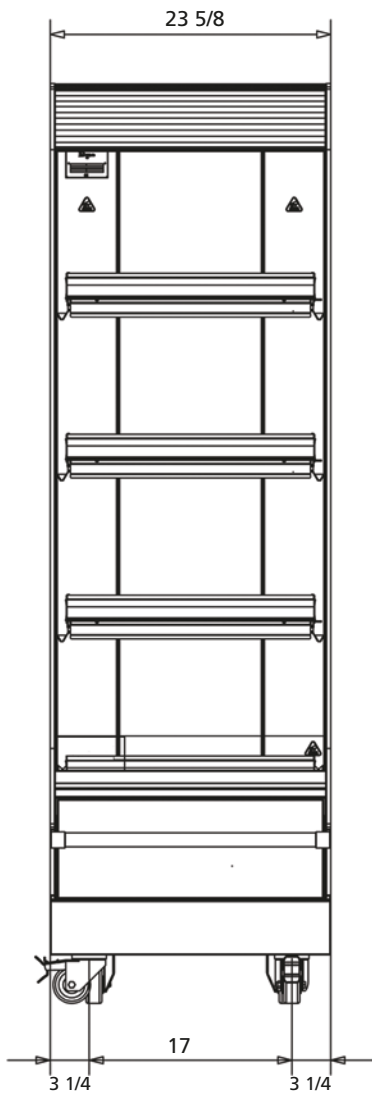
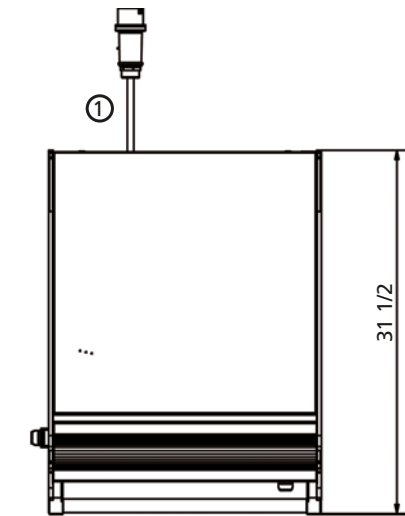

Fri-Jado Inc.
 1401 Davey Road
 Suite 100
 Woodridge IL 60517
 Toll free 877-374-5236
 Fax 630-689-1424
 e-mail us.info@frijado.com
usa.frijado.com

In-store impulse-generating merchandiser

Multi Deck 40 - 4 level



Placing impulse food products near checkouts has proven to be a successful strategy in today's grab-and-go market. With the Fri-Jado Multi Deck, your customers can pick up delicious, hot, pre-packaged snacks and meal solutions practically anywhere in the store.

Hot air is blown from the front of the shelf and circulates within the shelf surface resulting in optimum air circulation around the hot product.

Large glazed walls give a 180-degree view of the products. The appealing design gives outstanding product presentation which is sure to boost impulse sales.

Features MD 40 - 4 Premium

Top features

- Self-serve heated Multi Deck display unit
- Innovative airflow technology: no hot or cold spots
- Boosts impulse sales

Standard characteristics

- 40" - 4 level display
- Product temperature maintained at 149-158°F
- Ideal for chicken, wraps, snacks, soups etc.
- Upright design saves space
- Total display capacity of 18.9ft²
- Footprint of 8.6ft²
- Safety lighting on each level
- Shatter-resistant clear side glass for optimum safety and insulation
- Saves up to 20% on energy by air-curtain technology on each shelf
- Safe holding temperature for up to four hours
- Angled shelves provide optimum product visibility
- Illuminated changeable sign at top and price strips on each shelf
- Front bumpers to protect from shopping carts
- Solid back as standard
- 98% recyclable (environmentally friendly)
- Plug-and-play

Accessories

- Customer-side temperature indicator
- Lower skirts (covering wheels)

Optional

- Doors at rear (pass through)
- Front doors



Optimum product visibility



Signage



Rear doors (optional)



Keeps hot food above 149°F

MD 40-4 Premium

1 Power cable, 10 ft.

Dimensions

| | |
|--------|---------|
| Width | 39 3/8" |
| Depth | 31 1/2" |
| Height | 77 5/8" |

Technical data

| | |
|--------------|-------------|
| Net weight | 598 lbs |
| Gross weight | 710 lbs |
| Voltage | 3~208 V |
| Frequency | 60 Hz |
| Power | 5 kW |
| Plug | NEMA 15-20P |

Specifications and technical data are subject to amendment without notice.

These are basic drawings. For more detailed technical information, please refer to the installation manual at www.frijado.com.

Patent number: EP2309897

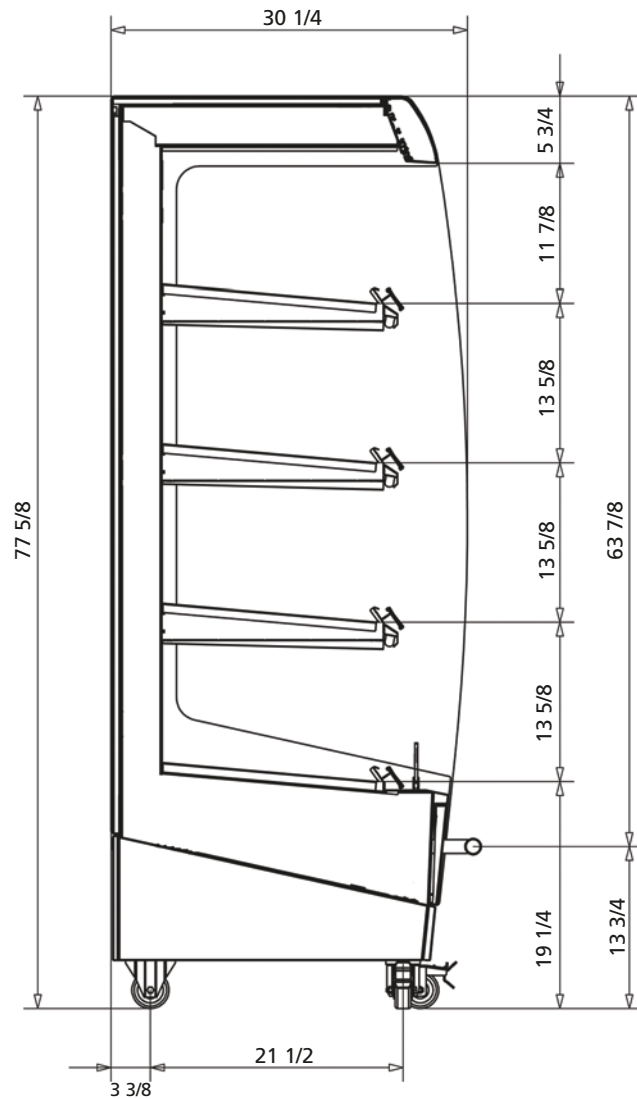
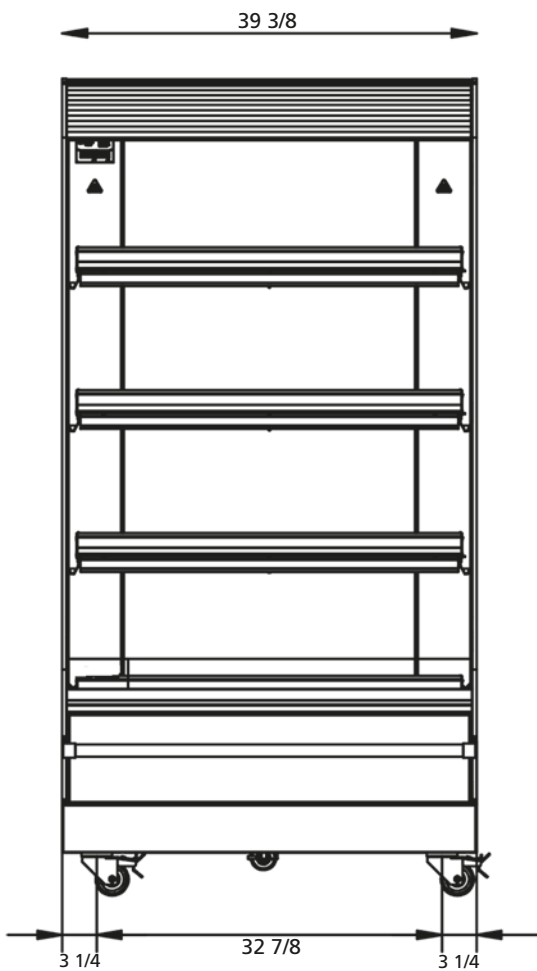
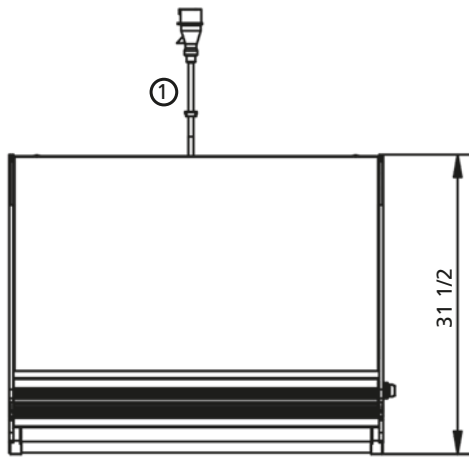

Fri-Jado Inc.
 1401 Davey Road
 Suite 100
 Woodridge IL 60517
 Toll free 877-374-5236
 Fax 630-689-1424
 e-mail us.info@frijado.com
usa.frijado.com



In-store impulse-generating merchandiser

Multi Deck 48 - 4 level



Placing impulse food products near checkouts has proven to be a successful strategy in today's grab-and-go market. With the Fri-Jado Multi Deck, your customers can pick up delicious, hot, pre-packaged snacks and meal solutions practically anywhere in the store.

Hot air is blown from the front of the shelf and circulates within the shelf surface resulting in optimum air circulation around the hot product.

Large glazed walls give a 180-degree view of the products. The appealing design gives outstanding product presentation which is sure to boost impulse sales.

Features MD 48 - 4 Premium

Top features

- Self-serve heated Multi Deck display unit
- Innovative airflow technology: no hot or cold spots
- Boosts impulse sales

Standard characteristics

- 48" wide - 4 level display
- Product temperature maintained at 149-158°F
- Ideal for chicken, wraps, snacks, soups etc.
- Upright design saves space
- Total display capacity of 22.819ft²
- Footprint of 10.333ft²
- Safety lighting on each level
- Shatter-resistant clear side glass for optimum safety and insulation
- Saves up to 20% on energy by air-curtain technology on each shelf
- Safe holding temperature for up to four hours
- Angled shelves provide optimum product visibility
- Illuminated changeable sign at top and price strips on each shelf
- Front bumpers to protect from shopping carts
- Solid back as standard
- 98% recyclable (environmentally friendly)
- Plug-and-play

Accessories

- Customer-side temperature indicator
- Lower skirts (covering wheels)
- Cross-selling drawer

Optional

- Doors at rear (pass through)
- Front doors



Optimum product visibility



Signage



Rear doors (optional)



Keeps hot food at 149°F

MD 48-4 Premium

1 Power cable, 10 ft.

Dimensions

| | |
|--------|---------|
| Width | 47 1/4" |
| Depth | 31 1/2" |
| Height | 77 5/8" |

Technical data

| | |
|--------------|-------------|
| Net weight | 654 lbs |
| Gross weight | 776 lbs |
| Voltage | 208 V |
| Frequency | 60 Hz |
| Power | 6.6 kW |
| Plug | NEMA 15-30P |

Specifications and technical data are subject to amendment without notice.

These are basic drawings. For more detailed technical information, please refer to the installation manual at www.frijado.com.

Patent number: EP2309897

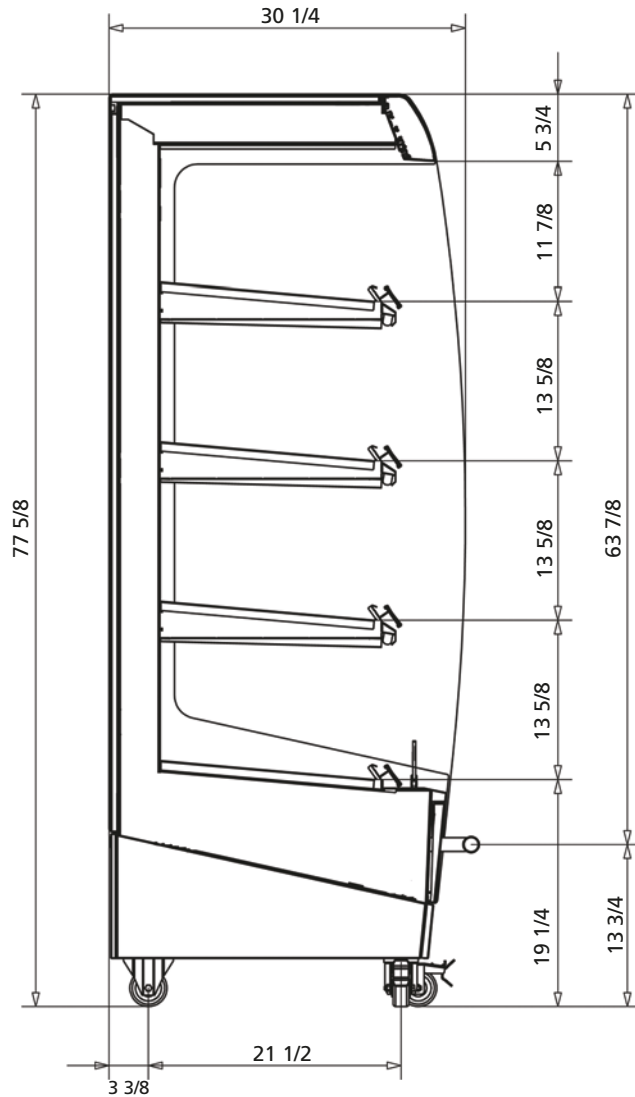
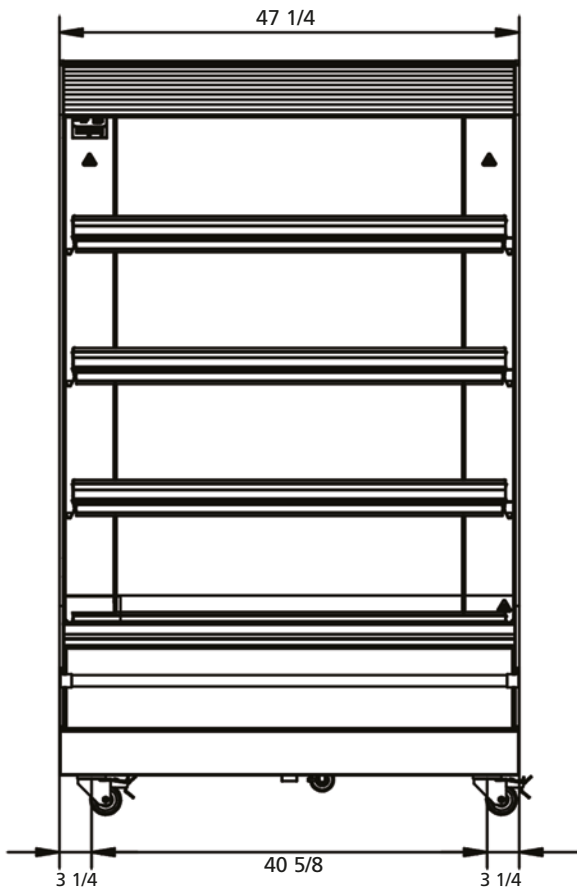
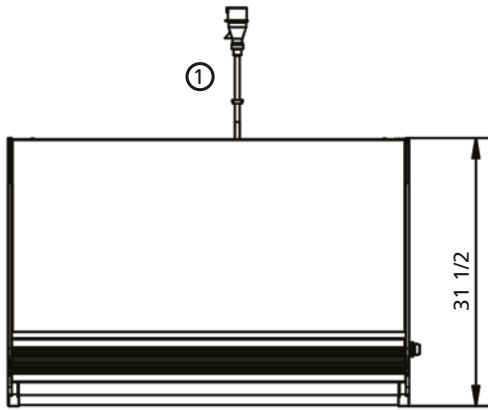

Fri-Jado Inc.
 1401 Davey Road
 Suite 100
 Woodridge IL 60517
 Toll free 877-374-5236
 Fax 630-689-1424
 e-mail us.info@frijado.com
usa.frijado.com

