

# In-store impulse-generating merchandiser

Multi Deck 60 - 5 level



**Placing impulse food products near checkouts has proven to be a successful strategy in today's grab-and-go market. With the Fri-Jado Multi Deck, your customers can pick up delicious, hot, pre-packaged snacks and meal solutions practically anywhere in the store.**

Hot air is blown from the front of the shelf and circulates within the shelf surface resulting in optimum air circulation around the hot product.

Large glazed walls give a 180-degree view of the products. The appealing design gives outstanding product presentation which is sure to boost impulse sales.

## Features MD 60-5 Premium

### Top features

- Self-serve heated Multi Deck display unit
- Illuminated changeable sign at top and price strips on each shelf
- Changeable price strips on each shelf
- Safety lighting on each level
- Innovative airflow technology: consistent holding temperature
- Boosts impulse sales

### Standard characteristics

- 60 cm wide - 5 level display
- Product temperature maintained at 65-70°C
- Ideal for chicken, wraps, snacks, soups etc.
- Upright design saves space
- Total display capacity of 1.3 m<sup>2</sup>
- Footprint of 0.5 m<sup>2</sup>
- Shatter-resistant clear side glass for optimum safety
- Saves up to 20% on energy by air-curtain technology on each shelf
- Safe holding temperature for up to four hours
- Angled shelves provide optimum product visibility
- Front bumpers to protect from shopping carts
- Solid back as standard
- 98% recyclable (environmentally friendly)
- Plug-and-play

### Accessories

- Customer-side temperature indicator
- Lower skirts (covering wheels)

### Optional

- Doors at rear (pass through)
- Front doors



Optimum product visibility



Signage



Rear doors (optional)



Keeps hot food at 65-70°C

## MD 60-5 Premium

1 Power cable, 2,5 m

### Dimensions

Width	600 mm
Depth	800 mm
Height	1972 mm

### Technical data

Net weight	209 kg
Gross weight	246 kg
Voltage	3N~ 400/230 V
Frequency	50/60 Hz
Power	3.6 kW

Specifications and technical data are subject to amendment without notice.

These are basic drawings. For more detailed technical information, please refer to the installation manual at [www.frijado.com](http://www.frijado.com).

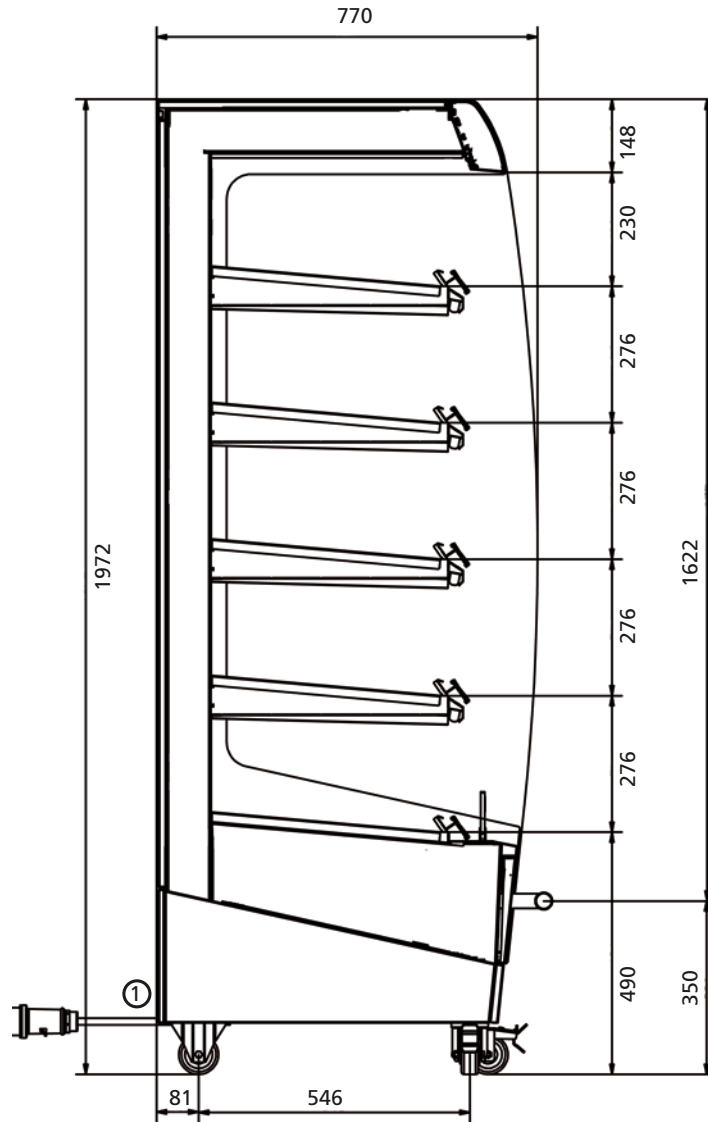
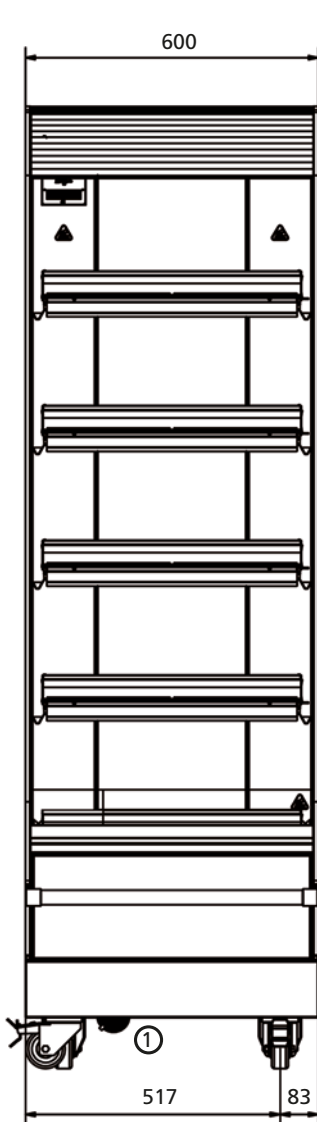
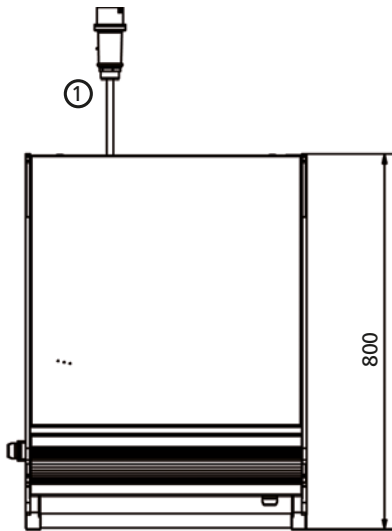

# In-store impulse-generating merchandiser

Multi Deck 100 - 5 level



**Placing impulse food products near checkouts has proven to be a successful strategy in today's grab-and-go market. With the Fri-Jado Multi Deck, your customers can pick up delicious, hot, pre-packaged snacks and meal solutions practically anywhere in the store.**

Hot air is blown from the front of the shelf and circulates within the shelf surface resulting in optimum air circulation around the hot product.

Large glazed walls give a 180-degree view of the products. The appealing design gives outstanding product presentation which is sure to boost impulse sales.

## Features MD 100 - 5 Premium

### Top features

- Self-serve heated Multi Deck display unit
- Illuminated changeable sign at top and price strips on each shelf
- Changeable price strips on each shelf
- Safety lighting on each level
- Innovative airflow technology: consistent holding temperature
- Boosts impulse sales

### Standard characteristics

- 100 cm wide - 5 level display
- Product temperature maintained at 65-70°C
- Ideal for chicken, wraps, snacks, soups etc.
- Upright design saves space
- Total display capacity of 2.205 m<sup>2</sup>
- Footprint of 0.8 m<sup>2</sup>
- Shatter-resistant clear side glass for optimum safety
- Saves up to 20% on energy by air-curtain technology on each shelf
- Safe holding temperature for up to four hours
- Angled shelves provide optimum product visibility
- Front bumpers to protect from shopping carts
- Solid back as standard
- 98% recyclable (environmentally friendly)
- Plug-and-play

### Accessories

- Customer-side temperature indicator
- Lower skirts (covering wheels)

### Optional

- Doors at rear (pass through)
- Front doors



Optimum product visibility



Signage



Rear doors (optional)



Keeps hot food at 65-70°C

## MD 100-5 Premium

1 Power cable, 2 m

### Dimensions

Width	1000 mm
Depth	800 mm
Height	1972 mm

### Technical data

Net weight	274 kg
Gross weight	322 kg
Voltage	3N~ 400/230 V
Frequency	50/60 Hz
Power	5.4 kW

Specifications and technical data are subject to amendment without notice.

These are basic drawings. For more detailed technical information, please refer to the installation manual at [www.frijado.com](http://www.frijado.com).

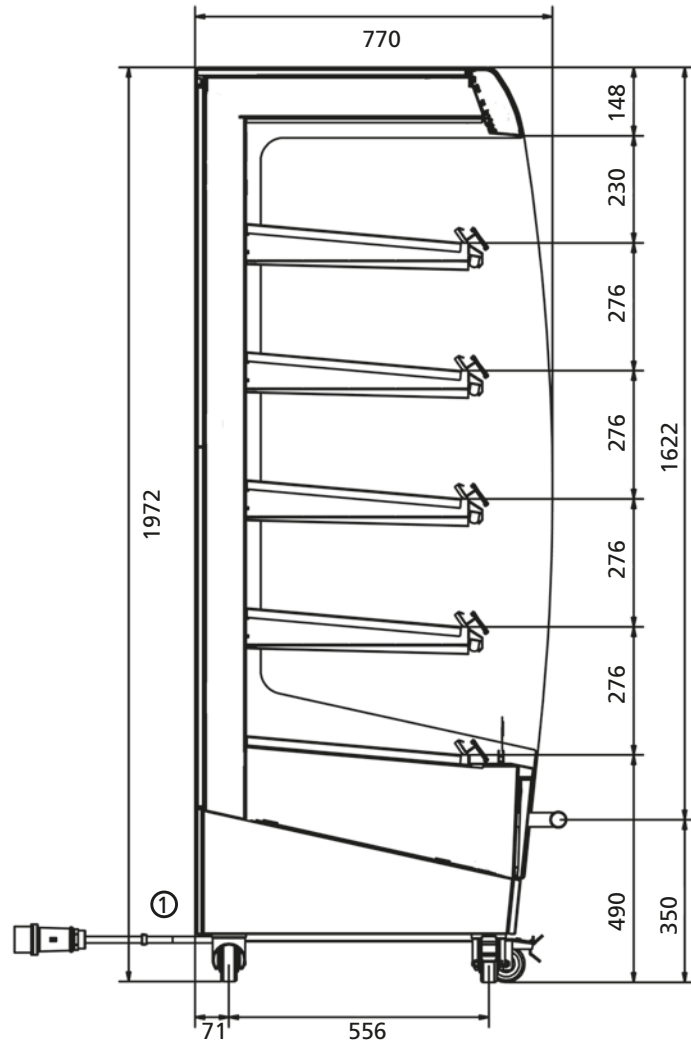
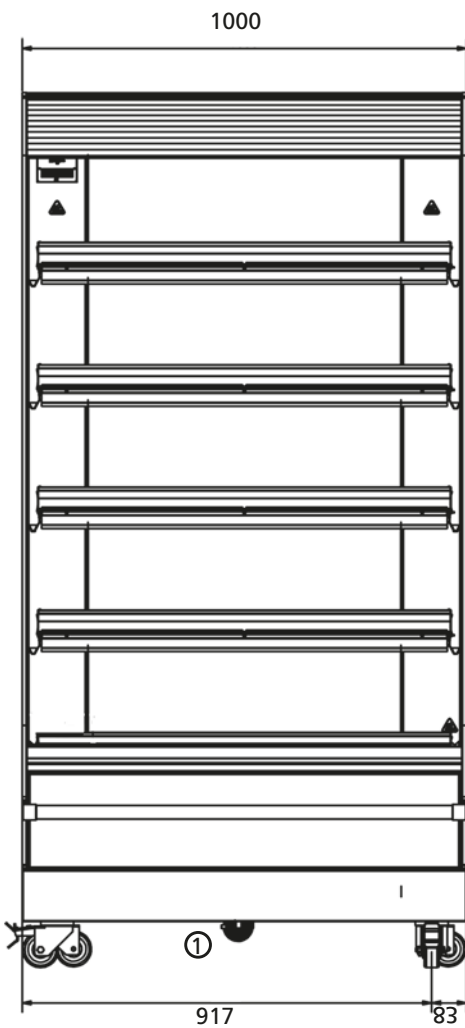
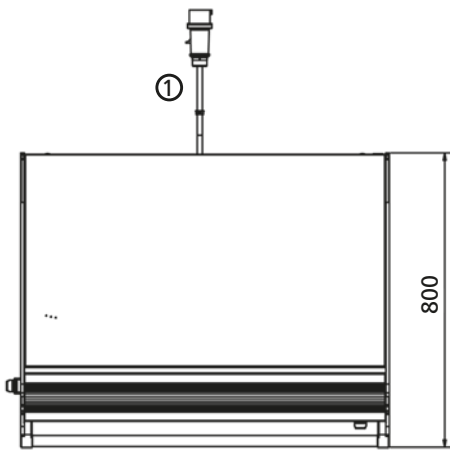

# In-store impulse-generating merchandiser

Multi Deck 120 - 5 level



**Placing impulse food products near checkouts has proven to be a successful strategy in today's grab-and-go market. With the Fri-Jado Multi Deck, your customers can pick up delicious, hot, pre-packaged snacks and meal solutions practically anywhere in the store.**

Hot air is blown from the front of the shelf and circulates within the shelf surface resulting in optimum air circulation around the hot product.

Large glazed walls give a 180-degree view of the products. The appealing design gives outstanding product presentation which is sure to boost impulse sales.

## Features MD 120-Premium

### Top features

- Self-serve heated Multi Deck display unit
- Illuminated changeable sign at top and price strips on each shelf
- Changeable price strips on each shelf
- Safety lighting on each level
- Innovative airflow technology: consistent holding temperature
- Boosts impulse sales

### Standard characteristics

- 120 cm wide - 5 level display
- Product temperature maintained at 65-70°C
- Ideal for chicken, wraps, snacks, soups etc.
- Upright design saves space
- Total display capacity of 2.655 m<sup>2</sup>
- Footprint of 0.96 m<sup>2</sup>
- Shatter-resistant clear side glass for optimum safety and insulation
- Saves up to 20% on energy by air-curtain technology on each shelf
- Safe holding temperature for up to four hours
- Angled shelves provide optimum product visibility
- Front bumpers to protect from shopping carts
- Solid back as standard
- 98% recyclable (environmentally friendly)
- Plug-and-play

### Accessories

- Customer-side temperature indicator
- Lower skirts (covering wheels)

### Optional

- Doors at rear (pass through)
- Front doors



Optimum product visibility



Signage



Rear doors (optional)



Keeps hot food at 65-70°C

## MD 120-5 Premium

1 Power cable, 2 m

### Dimensions

Width	1200 mm
Depth	800 mm
Height	1972 mm

### Technical data

Net weight	300 kg
Gross weight	353 kg
Voltage	3N~ 400/230 V
Frequency	50/60 Hz
Power	6.5 kW

Specifications and technical data are subject to amendment without notice.

These are basic drawings. For more detailed technical information, please refer to the installation manual at [www.frijado.com](http://www.frijado.com).

